

# DESIRE POLE - ASSEMBLY INSTRUCTIONS

M BISSELL DISPLAY LTD  
Tel: 01543 502115 Fax: 01543 502111

## Aluminium POLE (3600mm long)

screwports accept self-tapping screws (No. 10 x 12mm) to fix on the top cap

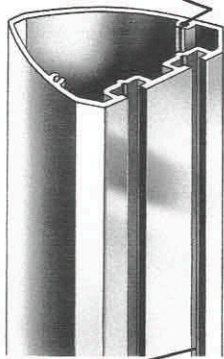

channels accept square-head fixing bolts plus coloured plastic infill strips (optional)

## Aluminium FLAG ANGLES (same length as flags)

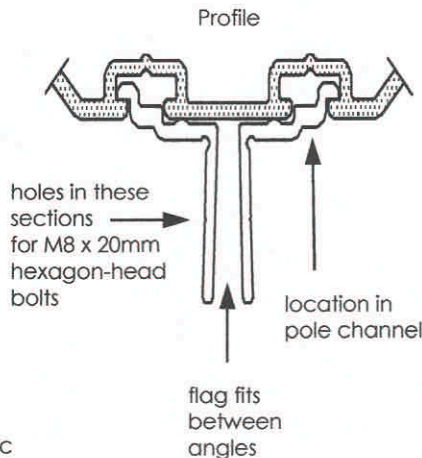

## Plastic SPACER PANEL for timetable case (not always needed - see note 4)



holes for M8 x 22mm square-head bolts to pass through and into the timetable case

## Aluminium UNDERGROUND POLE SOCKET (600mm long)

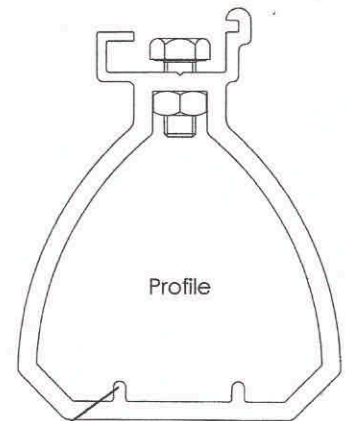

nibs keep infill strips on top of socket.

Clamping bolt is set-down 20mm from top

### PLEASE READ ALL INSTRUCTIONS BEFORE PROCEEDING

1. Our standard pole is 3600mm long. Our standard flag is 600mm long though customer requirements often vary. The Dept for Transport suggests 2300mm (minimum) between ground level and flag; using our standards this leaves 700mm for below ground, less would raise the flag higher unless you shorten the pole. Check pole ends for damage (rare) before deciding which end to put into the ground. If using our underground socket then 600mm of the pole should sit within it. The life of the pole/underground socket will be prolonged if the surface area that comes into contact with the concrete infill is coated with bituminous paint. Contact with any other metals (other than our fittings) must be avoided.
2. **INSTALLATION WITHOUT UNDERGROUND SOCKET:** Mark your ground level line on the pole and then, from the end of the pole, slide an M8 x 22mm square-head bolt into each channel and fix with nut and washer at a point approx. 300mm below the line. These 'stabilising bolts' will prevent the pole being lifted out of the ground after installation.

**INSTALLATION WITH UNDERGROUND SOCKET** (see also separate page FOUNDATION REQUIREMENTS): The adhesive-backed vinyl 'wrap' is for covering the base/lower periphery of the socket so that your concrete infill will not intrude. The socket has an indentation mid-rear to prevent it being lifted out of the ground.

Clamp your pole in the socket using the rear bolt (torque setting 5 Nm) then pop-riquet the Bolt-Head Cover to the socket (see separate ASSEMBLY DRAWING). The bottom edge of the cover determines the ground level - if you prefer the socket flush to the ground you will need to secure the pole prior to final surfacing.

3. **OPTIONAL CHANNEL INFILL STRIPS - THE LOWER STRIPS** sit between the timetable case and the ground and their length will be this distance plus a further 70mm to be concealed behind the case. Take note, however, that when using our underground socket the strips will rest on top of the socket nibs (see illustration above). Cut the infills to length with scissors (one from each of the 2 strips), remove the protective film and slide into each channel.

If you are not using our underground socket but wish to fit these strips prior to installation then you have the option to fix an M8 x 22mm square-head bolt in each channel to act as 'stops'. Position these at say 25mm below your ground level line (i.e. above your intended concrete level) so that in the future you can remove/replace the infill strips (now 25mm longer).

4. Insert 4 M8 x 22mm square-head bolts from the top of the pole (2 in each channel) and then over the exposed threads place the spacer panel followed by the timetable case. Slide the case to the required height and secure in position. NB. Only the 4 M8 x 22mm square-head bolts are needed when fitting cases with rear (horizontal) channels or when fitting our multiple-case brackets; the spacer panel is not required.
5. **OPTIONAL CHANNEL INFILL STRIPS - THE UPPER STRIPS** sit between the flag and timetable case. With the case in position slide in the 2 remaining strips and mark a cutting line on each one 30mm above where the bottom edge of the flag angles will be (see instruction 6 below). Remove, cut, take off the protective film and re-insert.
6. Screw on the top cap (or at any time previously) with the 2 self-tapping screws. Locate the flag angles in the pole channels as illustrated above and butt against the top cap. Until the flag has been bolted between them (using the 2 M8 x 20mm hexagon-head bolts) the angles will be free to move. To prevent the movement we suggest you clamp the flag angles together across the top or bottom edges with a bulldog clip (not supplied); you can then ease the flag inbetween from the opposite end. Once the flag is bolted in position the flag angles are held in place under substantial pressure though you can also pop-riquet the assembly to the pole if you wish via the corner of an angle (i.e. drill at 45°).